

ARM·A·DOR™

Installation Guide

Panic Hardware for Exit Doors

IMPORTANT INFORMATION

By following the simple steps in this installation guide, Arm-A-Dor™. Arm-A-Dor will be successfully installed in approximately one to two hours depending on model type and options. A drill template is provided to ensure Arm-A-Dor is installed correctly. Failure to use installation guide and drill template can cause Arm-A-Dor to operate improperly and/or cause excessive wear which will void 5 year warranty. A Low Profile Kit is required when installing Arm-A-Dor on door with door jamb depths greater than 6 3/4”.



UL 10B Fire Rated
New York City Building Code Approved
Dade County Product Approved
California Building Code Approved

dormakaba 

Corporate Headquarters
6161 East 75th Street
Indianapolis, IN 46250 USA

Technical Support: 800-392-5209
www.precisionhardware.com



PRECISION



Note STOP Symbols
in this installation guide.
If conditions are not as required,
DO NOT PROCEED
with installation.

ARM-A-DOR™

Completed Installations

LOW PROFILE
Jambs greater than 6 3/4"
(Low profile kit required
A104-001)

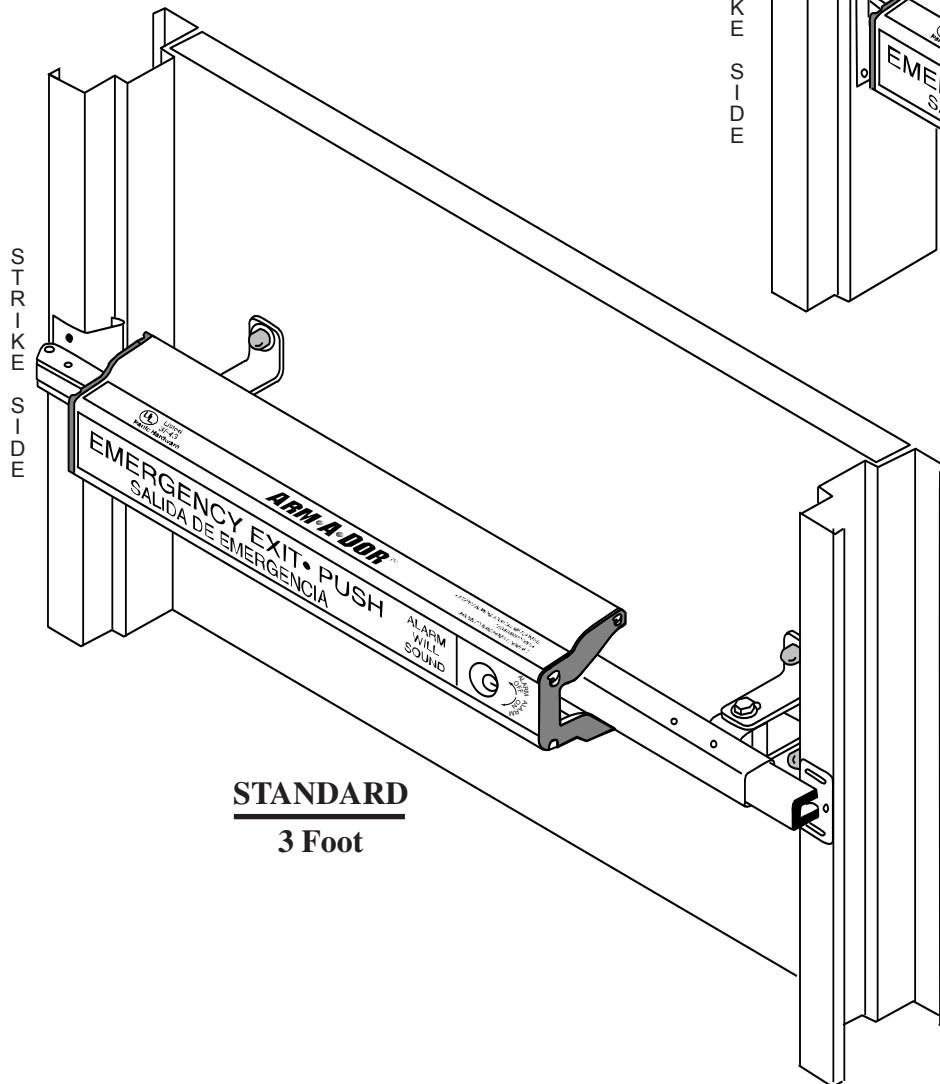

STANDARD
3 Foot

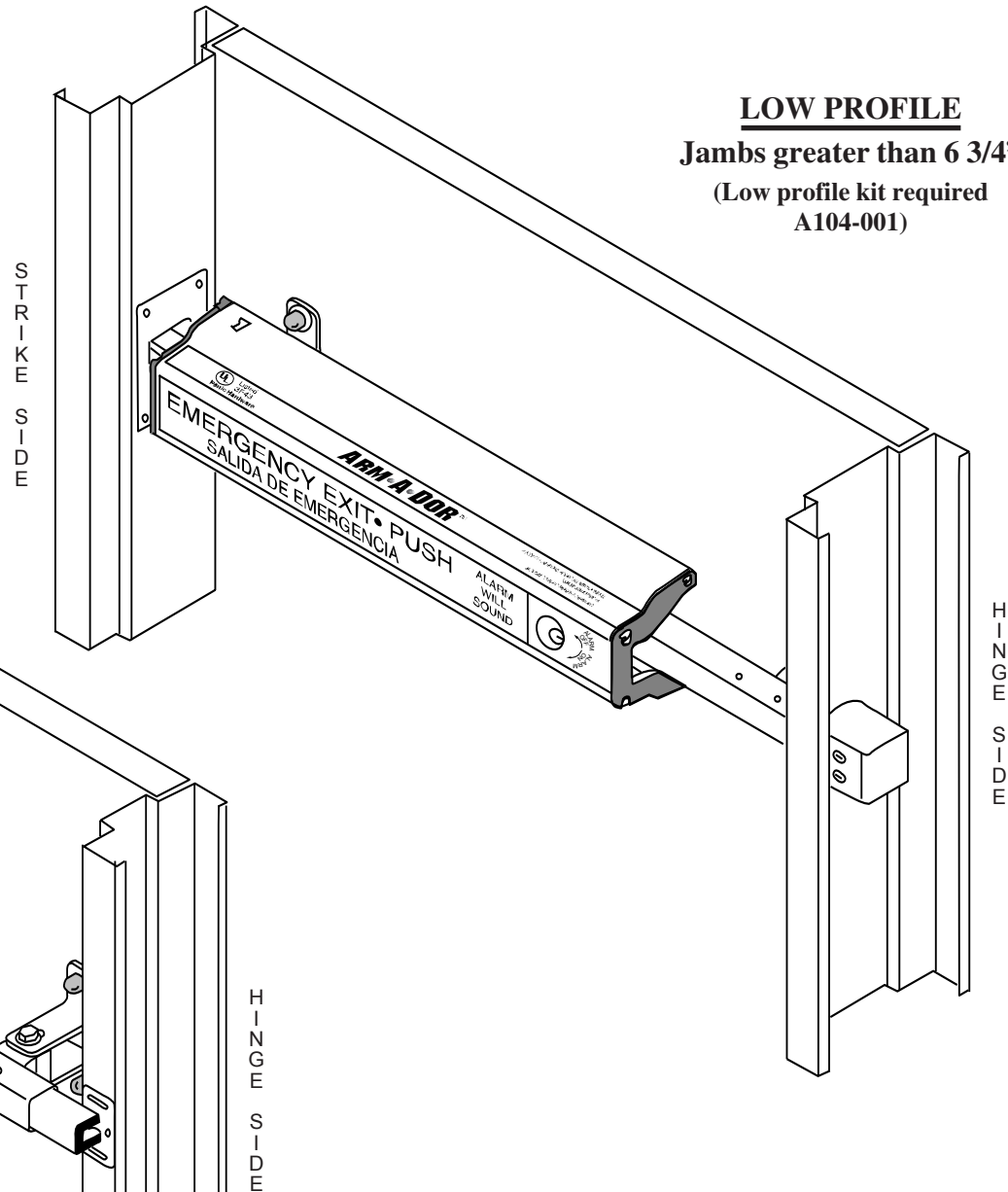

Table of Contents

A. Product Description

Models	2
Optional Accessory Kits	2

B. ADD Parts, Tools, and Supplies

Installation Tools and Supplies	2
AAD Standard and Fire-rated Parts	3
Checklist and Diagram.	4

C. Preparation

Inspecting Door and Door Frame.	5
Measuring Door and Door Frame	5
Determining Tailpiece, Tailpiece Collar, and Extension Rod Use and Length	6
Cutting Tailpiece	7
Cutting Extension Rod.	7

D. Assembling Lock

Assembling Extension Rod	7
Inserting Emergency Label	8
Installing Alarm Unit Mortise Cylinder, Emergency Label, and Batteries	9

E. Mounting Lock Assembly

Locating and Drilling Door Pilot Holes	11
Selecting and Securing Door Mounting Brackets	12
Selecting the Horizontal Mounting Position	13
Attaching Lock Assembly to Door.	14
Making Final Adjustments.	16
Securing the bolts.	16

F. Installing Strike Plate and Release Bracket

Installing Strike Plate.	16
Installing Release Bracket (Auto Units only)	17

G. Attaching the Tailpiece End Cap. 18

H. Checking Door and Alarm Operation

Checking Door Operation	18
Checking Alarm Operation (Alarm Units Only)	18

A. Product Description

ARM-A-DOR is code compliance Panic Hardware for exit doors. Manual, automatic-lock, and auto fire-rated models are available with or without alarms.

Model Nos.	Description
A101-001	Automatic Lock Assembly
A101-002	Automatic Lock Assembly with Alarm
A101-012	36" Automatic Lock Assembly
A101-013	36" Automatic Lock Assembly with Alarm
A101-F01	Auto Fire-rated Lock Assembly
A101-F02	Auto Fire-rated Lock Assembly with Alarm
A102-001	Manual Lock Assembly
A102-002	Manual Lock Assembly with Alarm

Optional Accessory Kits (not included)

Optional accessory kits enable Arm-A-Dor to connect with an existing site alarm, become AC-powered, adapt to double door applications, and adapt to doors with jamb depths greater than 6 3/4". AAD Accessory kits must be used when any of these applications are required.

Model Nos.	Description
A103-002	RX Switch Kit (integrates AAD with existing site alarm)
A104-001	Low Profile Kit (adapts AAD to door jamb depths greater than 6 3/4")
A106-001	Double Door Adapter Kit
A106-002	Low Profile Double Door Kit
A107-001	AC Adapter Kit
A107-002	AC Adapter Hard Wire Kit

B. ARM-A-DOR Parts, Tools and Supplies



Before installing ARM-A-DOR, verify all parts are included in the box (Reference Table 2 and Figure 1) and all necessary tools and supplies are available for installation (Reference Table 1). Also determine if any of the accessory kits are required. If any parts are missing or damaged, or an accessory kit is required, contact place of purchase, or BEST Access Solutions, Inc. Technical Support at 1-800-392-5209.

Table 1 Tools and Supplies Checklist

Minimum Tools Required

- 1/2" drive power drill
- 1/8" drill bit
- 1/4" drill bit
- 3/8" drill bit
- 1/8" masonry drill bit
- 5/16" nut driver (for drill)
- 5/8" hole saw with 1/4" pilot bit
- 2' level
- file
- wrenches (two 9/16")
- phillips screwdriver bit (for drill)
- hacksaw with 18-tooth blade
- pencil or marker
- measuring tape
- hammer
- center punch

Additional Supplies

- Alarm Models:
- one 1 1/8" mortise cylinder with straight cam (not included)

B. ARM-A-DOR Parts, Tools and Supplies (con't)

Table 2 STANDARD and FIRE-RATED Parts Check List

Item No.	Part No.	Part Description	Quantity STD / FIRE	
1		Lock assembly	2	2
2	A101-128	Tailpiece (see Table III)	1	1
3	A101-129	Extension rod (auto units only, see Table III)	1	1
4	A101-148*	Thread-cutting screw (#6 x 3/8)	8	8
5	A101-134	End cap for tailpiece	1	1
6	A101-126	Long door bracket (3 1/2" x 2")	4	6
7	A101-148*	Hex head bolt (3/8" x 2 1/2")	2	4
8	A101-148*	Flat washer (3/8")	8	12
9	A101-148	Star lock washer (3/8")	4	7
10	A101-148*	Hex nut (3/8"-16)	6	9
11	A101-120	Support sleeve (1 1/4")	2	3
12	A101-148*	Carriage bolt (3/8" x 2 1/2")	4	6
13	A101-133	Support tube (1 5/8")	4	6
14	A101-132	Bolt washer	4	6
15	A101-125	Strike plate	1	1
16	A101-127	Release bracket (auto units only)	1	1
17	A101-148*	Self-tapping screw (#10 x 3/4")	5	5

Item No.	Part No.	Part Description	Quantity STD / FIRE	
**18	630-335	Drill template	1	1
19	A101-026	End cap	2	2
20	A101-148*	Machine screw (#6 x 5/8")	8	8
21A	*See Below	Emergency label (One Piece)	—	—
21B	*See Below	Emergency label (alarm units only, two pieces)	1	1
22	A101-130	Tailpiece collar	1	1
23	A101-148*	Split lock washer (3/8")	2	2
24	A101-148*	Star lock washer (#10)	5	5
25	A101-143	Door bracket spacer	4	6
26	A101-126	Short door bracket (1 1/2" x 2")	4	6
27	A101-148*	Carriage bolt (3/8" x 3 1/2")	4	6
28	A101-148*	Gray vinyl cap	4	6
**—	—	9 - Volt alkaline battery	2	2

* Label Breakdown:

21A Use: A101-029 Non-Alarm for Models A101-001, A101-F01, A102-001

21B Use: A101-027 Alarm for Models A101-002, A101-F02, A102-002

** Not Shown in Parts Diagram.

* A101-148 is sold as a "Installation Kit" only. Individual parts not available.

Figure 1
Standard Parts Diagram

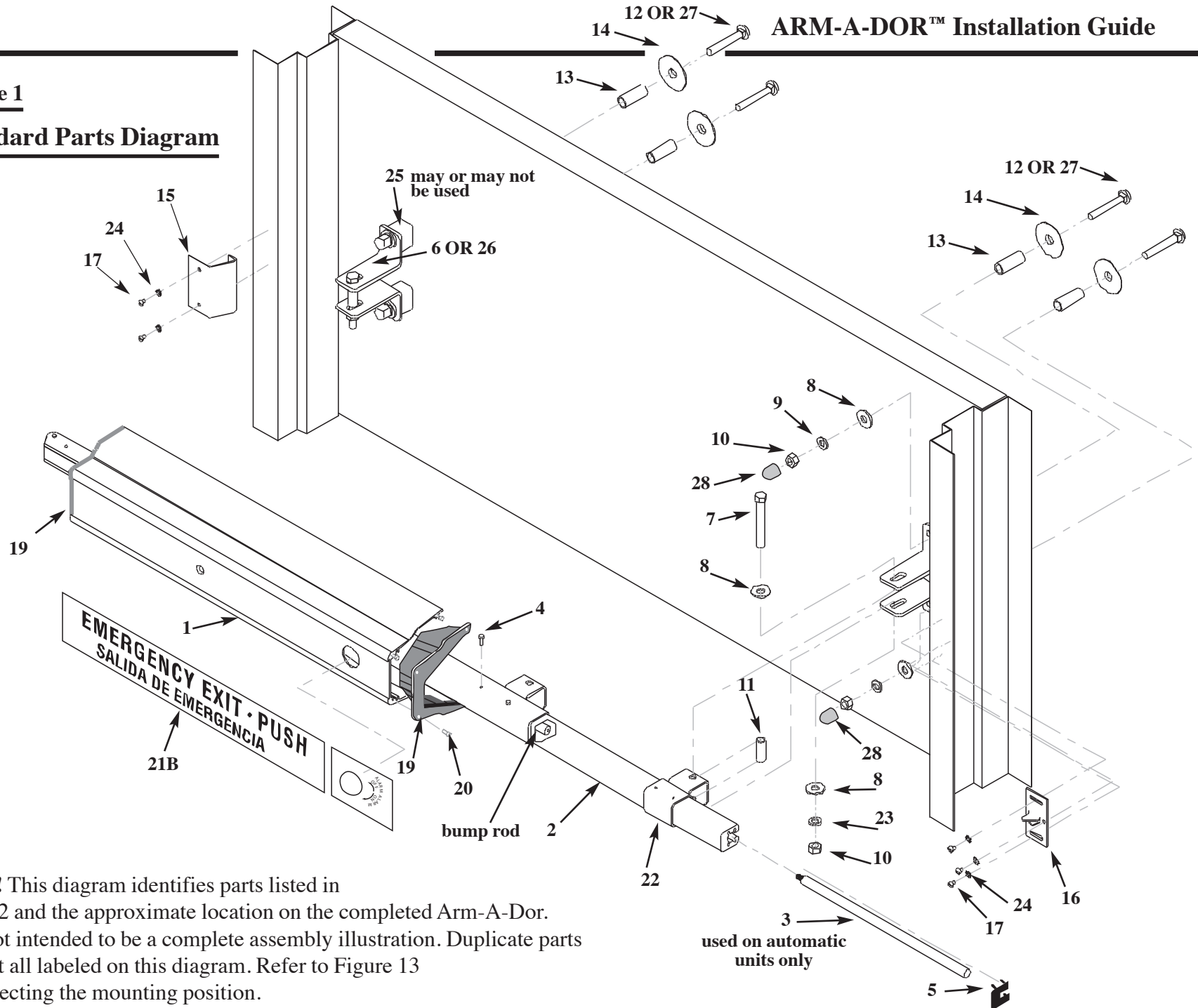

Note!! This diagram identifies parts listed in Table 2 and the approximate location on the completed Arm-A-Dor. It is not intended to be a complete assembly illustration. Duplicate parts are not all labeled on this diagram. Refer to Figure 13 for selecting the mounting position.

C. Preparation

Inspecting Door and Door Frame



1. Verify that door and door frame are in good condition and meet all building, fire, and security code requirements. Door must close completely within frame, and have door closer operating properly.
2. Fire labeled doors and frames require a fire rated Arm-A-Dor product.

Measuring Door and Door Frame

1. Measure and fill in below the dimensions of door width, door jamb depth and stop depth per Figure 2. If measurements vary from standard, additional steps will be required to ensure unit is installed correctly. Standard measurements noted in parenthesis.

Door Width (36"– 48") _____
(measure inside to inside)

Door Jamb Depth (3 3/4"– 6 3/4") _____
(If greater than 6 3/4", Low Profile Kit is needed)

Door Stop Depth (5/8") _____

Figure 2

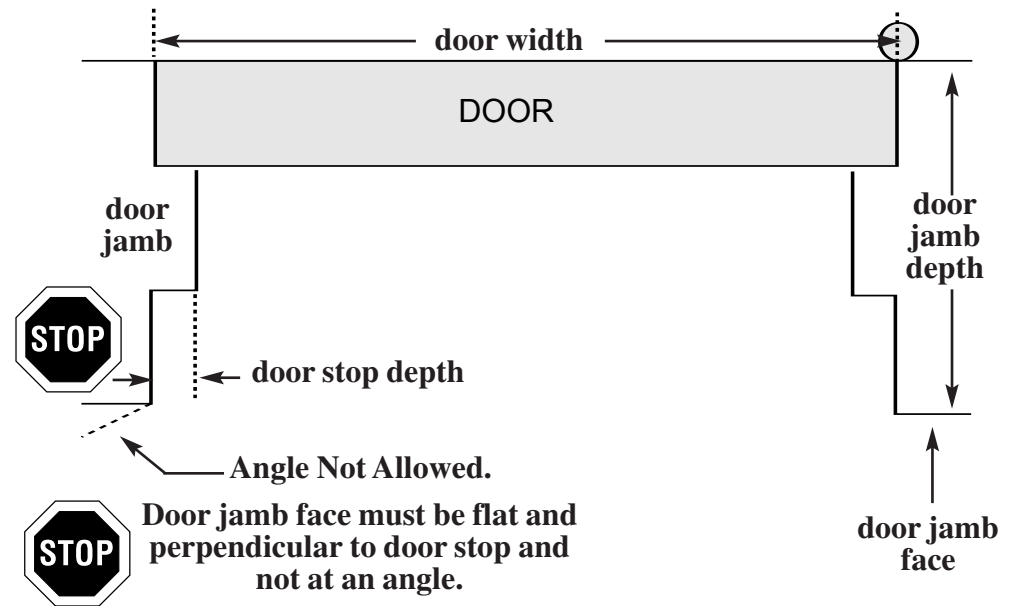

C. Preparation (con't)

Determining Tailpiece, Tailpiece Collar, and Extension Rod Use and Length



48” Door widths do not require cutting tailpiece or extension rod, continue to **step D, Assembling Lock.**

1. Locate the tailpiece (part no. 2) and, tailpiece collar (part no. 22). In addition automatic units, require extension rod (part no.3). Reference Figure 1 for assistance.
2. Use the door width measurement taken in previous step, and Table 3 below to determine:
 - A. Tailpiece length.
 - B. Extension rod length.
 - C. Tailpiece collar (use only on installations 40” and wider).
3. If tailpiece or extension rod require cutting continue to next step.

Table 3 Tailpiece, Extension Rod, Tailpiece Collar, and Tailpiece Protrusion Requirements

Door Width	Tailpiece Length	Extension Rod Length	Tailpiece Collar
36”	8”	Not used	NO
37”	9”	1”	NO
38”	10”	2”	NO
39”	11”	3”	NO
40”	12”	4”	YES
41”	13”	5”	YES
42”	14”	6”	YES
43”	15”	7”	YES
44”	16”	8”	YES
45”	17”	9”	YES
46”	18”	10”	YES
47”	19”	11”	YES
48”	AS SHIPPED	AS SHIPPED	YES

C. Preparation (con't)

Cutting Tailpiece

1. Measure and mark tailpiece to the correct length found during the door frame width measurement from Table 3.
2. Use a hacksaw to cut the tailpiece to the correct length.
3. Deburr the cut end.

Figure 3



Cutting Extension Rod (Automatic Unit Only)

1. Starting at the threaded end, measure and mark extension rod to the correct length determined from the door frame width measurement and Table 3. Reference Figure 4.
2. Use a hacksaw to cut from the unthreaded end of the extension rod to the correct length.
3. Deburr the cut end.

Figure 4

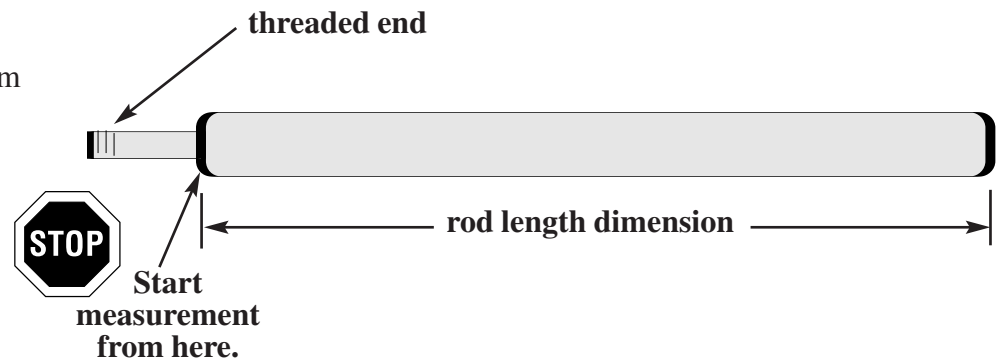

D. Assembling Lock

Assembling Extension Rod

For automatic units, thread the extension rod into the “bump rod” in the lock assembly as indicated in Figure 5. Hand tighten.

Figure 5

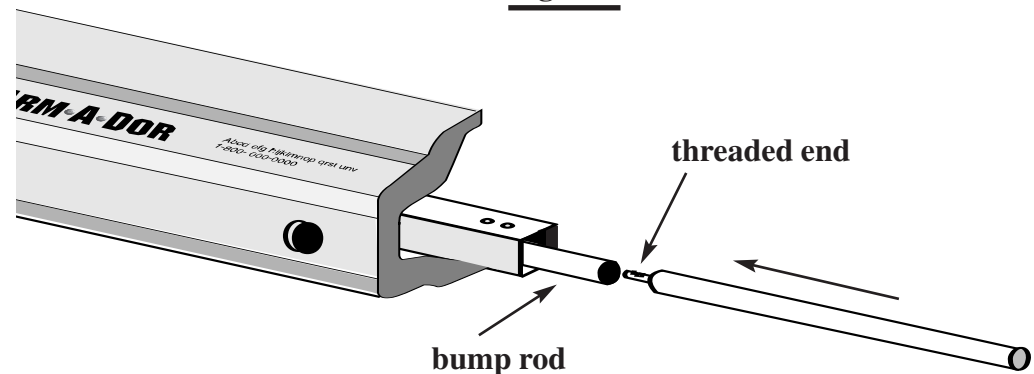

D. Assembling Lock (con't)

Assembling Tailpiece

1. Position the tailpiece with the open slot facing the door. Slip the tailpiece, field cut end first, (over the bump rod and/or extension rod on automatic units) and insert it into the lock assembly until it hits the stop. Reference Figure 6.
2. Drill four screw holes using a 1/8" drill, matching with the holes already in the lock assembly (two holes top and bottom). Align the holes and secure the tailpiece collar with four (4) thread cutting screws (part no. 4) using a Phillips screwdriver bit and drill.

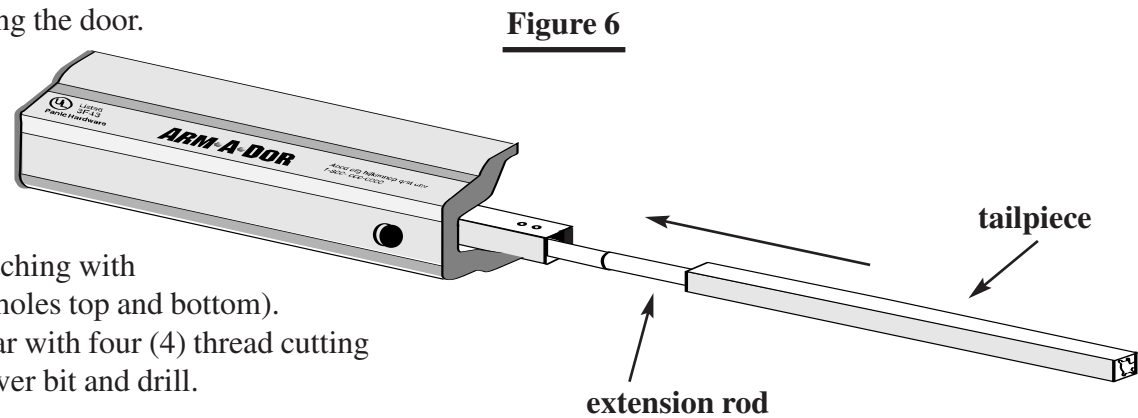

Inserting the Emergency Label (Non-Alarmed Model)

1. Locate emergency label (part no. 21A).
2. Remove the four (4) screws and the end cap (part no. 19) from the end of the push bar closest to the tailpiece.
3. Slide the label into the push bar as shown in Figure 7.
Ensure wording will be right side up after the lock assembly is installed.
4. Reattach end cap with the four (4) screws and continue to **Step E Attaching Lock**.

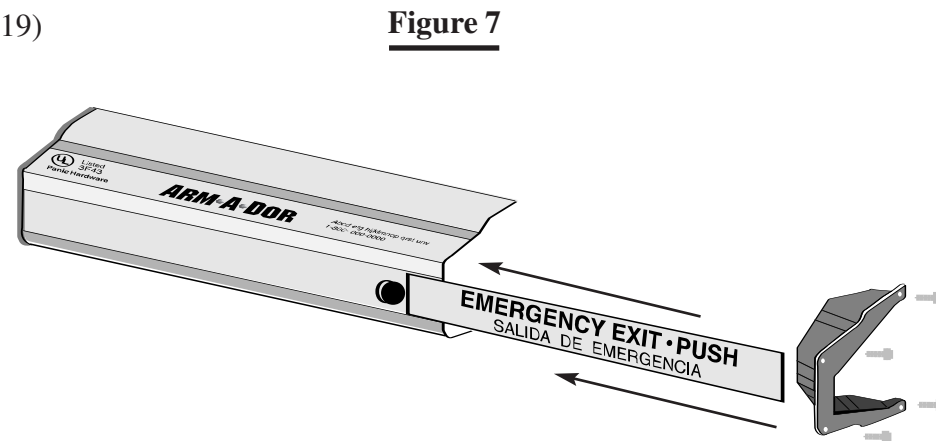

D. Assembling Lock (con't)

Installing Alarm Unit Mortise Cylinder, Emergency Label, and Batteries

Note: 1 1/8" Mortise Cylinder (not included) is required for this step.

1. Locate two piece emergency label (part no. 21B).
2. Remove the four (4) screws and the end cap from the end of the push bar closest to the cylinder end of push bar.
3. Slide off push bar to install batteries. Locate the two 9 -Volt alkaline batteries (included) and insert terminal end first into battery holder located on the opposite end of cylinder hole, making sure they snap into the holders.

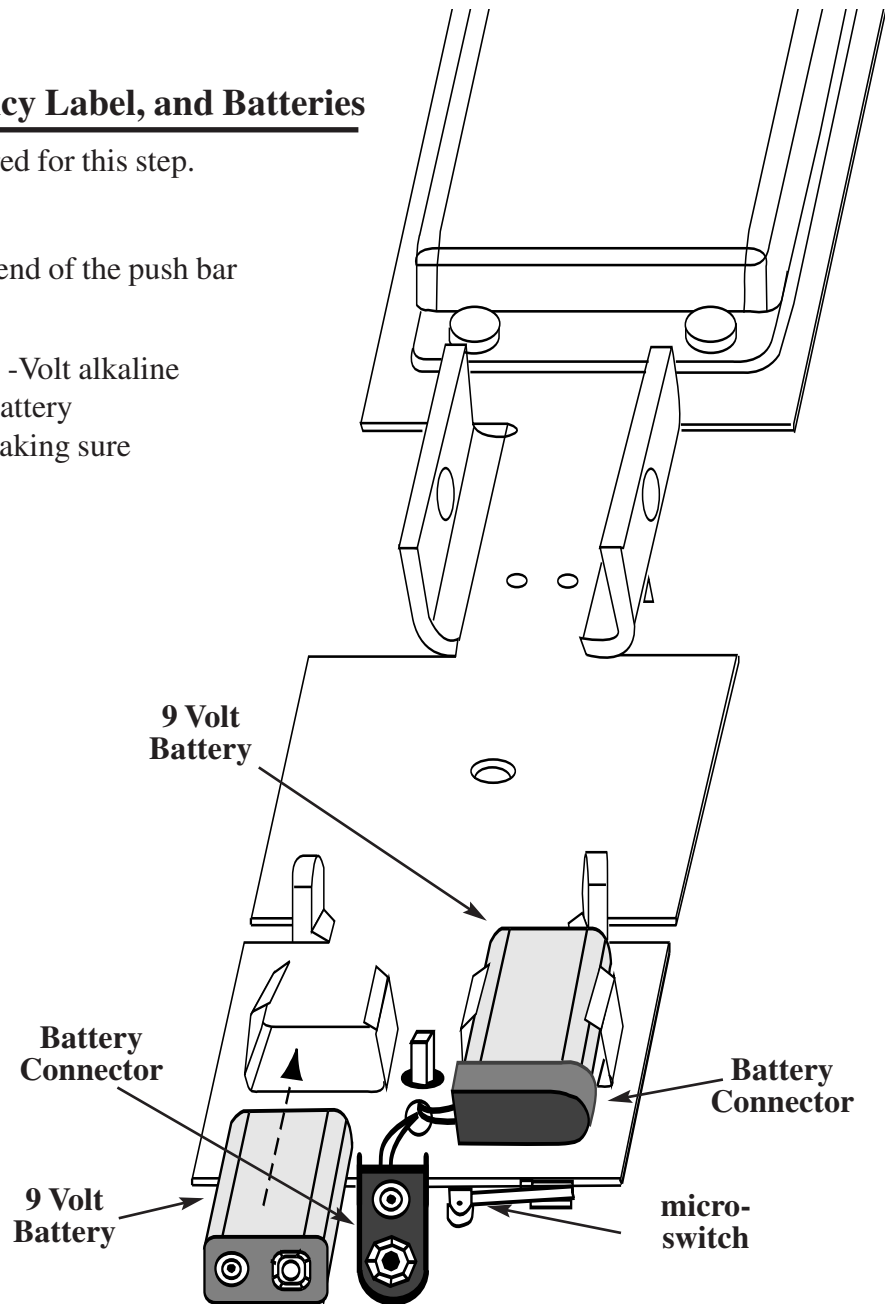

Figure 8

D. Assembling Lock (con't)

Installing Alarm Unit Mortise Cylinder, Emergency Label, and Batteries (con't)

4. Remove the screw, cylinder cover and cylinder retainer located at the end of the lock assembly behind the push bar. (Reference Figure 9).
5. Install long part of Emergency Label. Install short part of Emergency Label (part 21B). As shown in (Figure 9), screw in the 1 1/8" mortise cylinder. The cylinder keyway are pointed towards the hinged side of the door allowing the cam tailpiece to engage the switch slide. (Figure 10 is recommended cylinder cam style).
6. Align the cylinder retainer with the grooves in the cylinder and slide the retainer over the cylinder. Reattach cylinder cover and retainer with the single screw.
7. Reattach the end cap to the push bar with the same four (4) screws removed in earlier.
8. Turn the key to the armed positioned. The alarm will beep several times, then the LED in the middle of the push bar will flash RED every ten (10) seconds, indicating the system is armed. Disarm the alarm until you finish the installation.

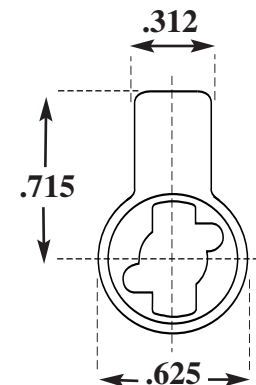
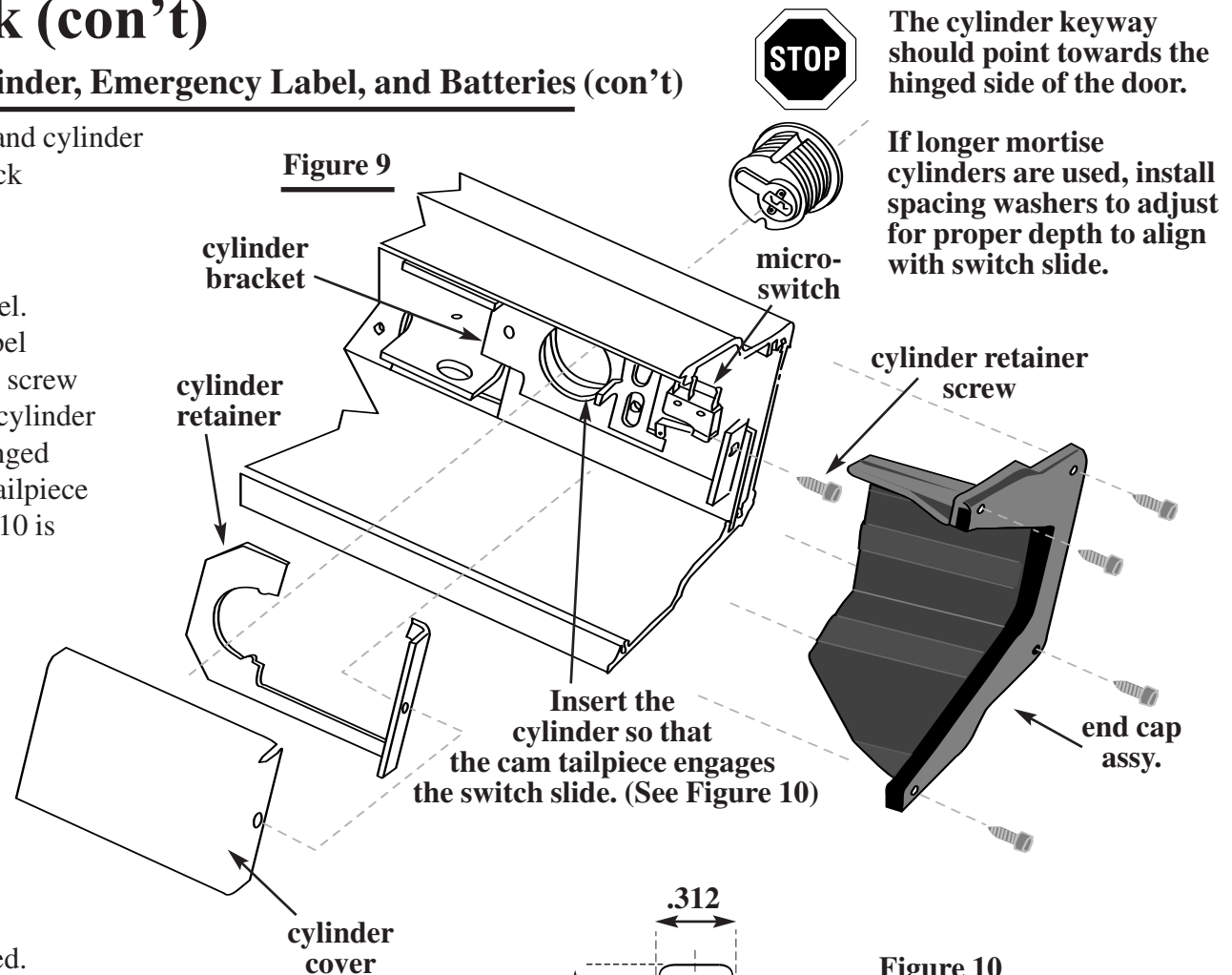

Figure 10
#CT-Z02
Standard Yale
type.
cylinder cam

E. Mounting Lock Assembly

Measure and Drill Pilot Holes

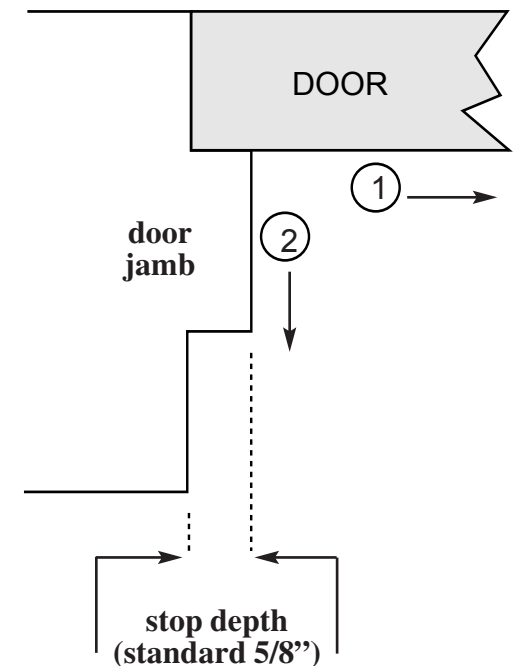

1. Determine the appropriate mounting height of lock from floor (typically 30" to 44", refer to local code requirements), then mark the selected height on both sides of the door frame.
2. Transfer each mark to the inside of the door and use as a guide to draw a level line across the door. Check with 2' level.
3. Locate large drill template (part no. 18) and fold it along the indicated fold line.
4. Drill template placement is determined by door stop depth.
 1. With door closed, align the "hinged" side of the template on the hinge side of the door.
 2. Align the opposite end of the template with the inside edge of the strike side and go to step 5.
5. Align the template's "center line" with the horizontal line mark across door.
6. Verify the template's alignment with the edge positions.
Hold template to door by using the two magnets (item 29).
7. Identify hole positions based on the door width measurement recorded on page 5.
8. Using a center punch, mark the four (4) hole positions. Remove template.
Note: If mounting a Fire-Rated model on a door over 40" wide, also mark hole positions for a 36" door (6 holes total).

Figure 11



E. Mounting Lock Assembly (con't)

Locating and Drilling Door Pilot Hole (con't)

9.  If door jamb depth is greater than 6 3/4", Low Profile Kit must be installed next.
10.  Using a 1/4" drill bit, carefully drill straight and level pilot holes through the marks made on the door. Drill slowly in the event there is reinforcement in the door. Drill completely **through the door**.
11. Using a 3/8" drill bit redrill pilot holes **through the inside skin of door only**.
12. Facing the outside of the door, locate the pilot holes and use a 5/8" hole saw to drill **only through the outside skin, any reinforcement, and insulation of door. Caution!! Stop drilling before reaching the inside skin of door.**

Selecting and Securing Door Mounting Brackets Spacers and Bolts

Figure 12

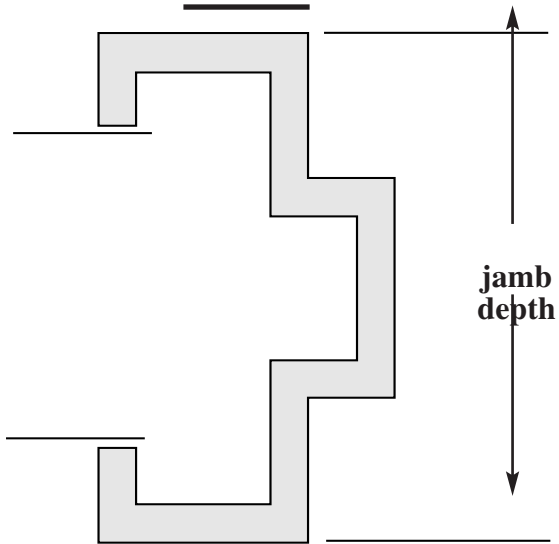

Table 4

Jamb Depth	Brackets Part Number	Door Bracket Spacers Part Number	Mounting Bolts / Pn.
3 3/4"	Short #26	NO	2 1/2" #12
4 3/4"	Short #26	YES #25	2 1/2" #12
*5 3/4"	Long #6	NO	3 1/2" #27
6 3/4"	Long #6	YES #25	3 1/2" #27
Over 6 3/4"	Short #26	NO	2 1/2" #12

* Most common size.

E. Mounting Lock Assembly (con't)

Selecting and Securing Door Mounting Brackets (con't)

1. Insert each selected carriage bolt (part no. 12 or 27) through a bolt washer (part no. 14) into a support tube (part no. 13), and then through the drilled holes on the outside of the door. Secure each bolt to the outside of the door with a piece of masking tape.
2. Place the door brackets (part no. 6 or 26) onto the carriage bolts protruding through the inside of the door.
3. Center each bracket on carriage bolt and secure with a flat washer (part no. 8), star lock washer (part no. 9), and hex nut (part no. 10). Hand tighten hex nuts, then remove tape from outside of door.

Figure 13

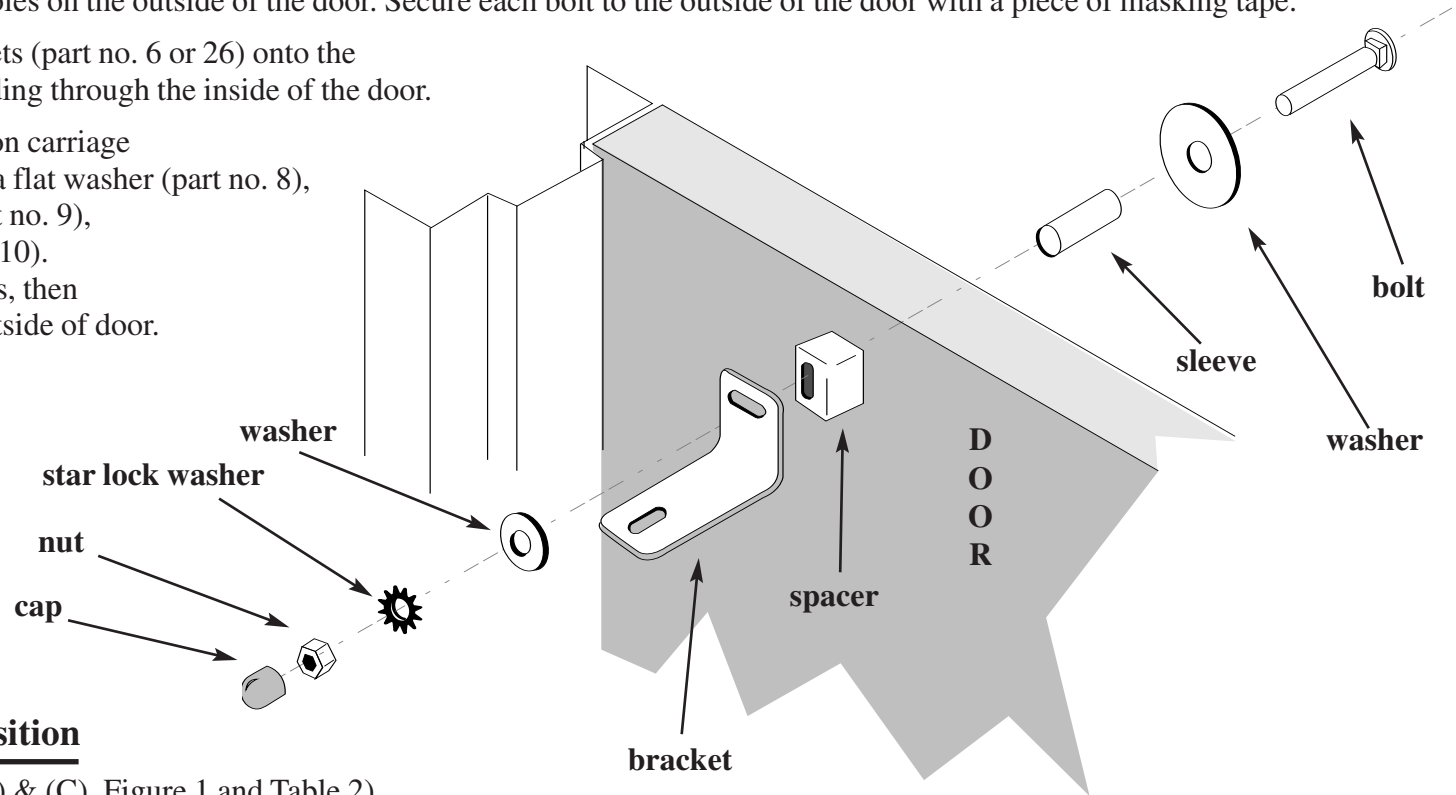

Selecting Mounting Position

(Reference Figure 14 (A) (B) & (C), Figure 1 and Table 2)

1. Determine mounting configuration as follows:
 - A. Figure 14 (A) for door widths under 40", use the two square brackets welded to the lock assembly.
 - B. Figure 14 (B) for door widths 40" or greater use only the square bracket closest to the roller bearing on the lock assembly, and the tailpiece collar (part no. 22).
 - C. Figure 14 (C) for Fire-rated models mounted on doors over 40" wide use the two square brackets and the tailpiece collar (part no. 22).

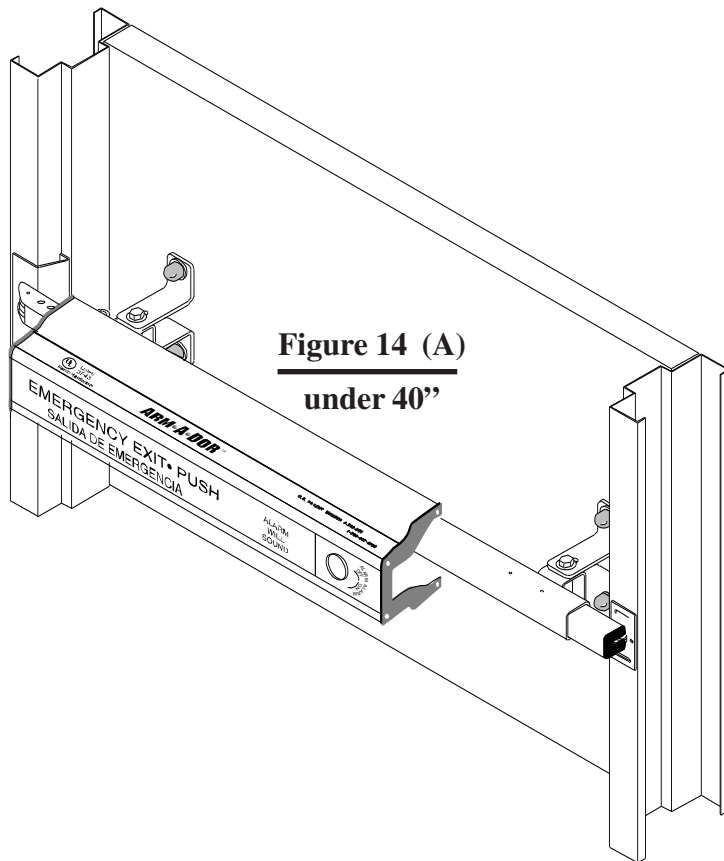

Figure 14 (A)
under 40"

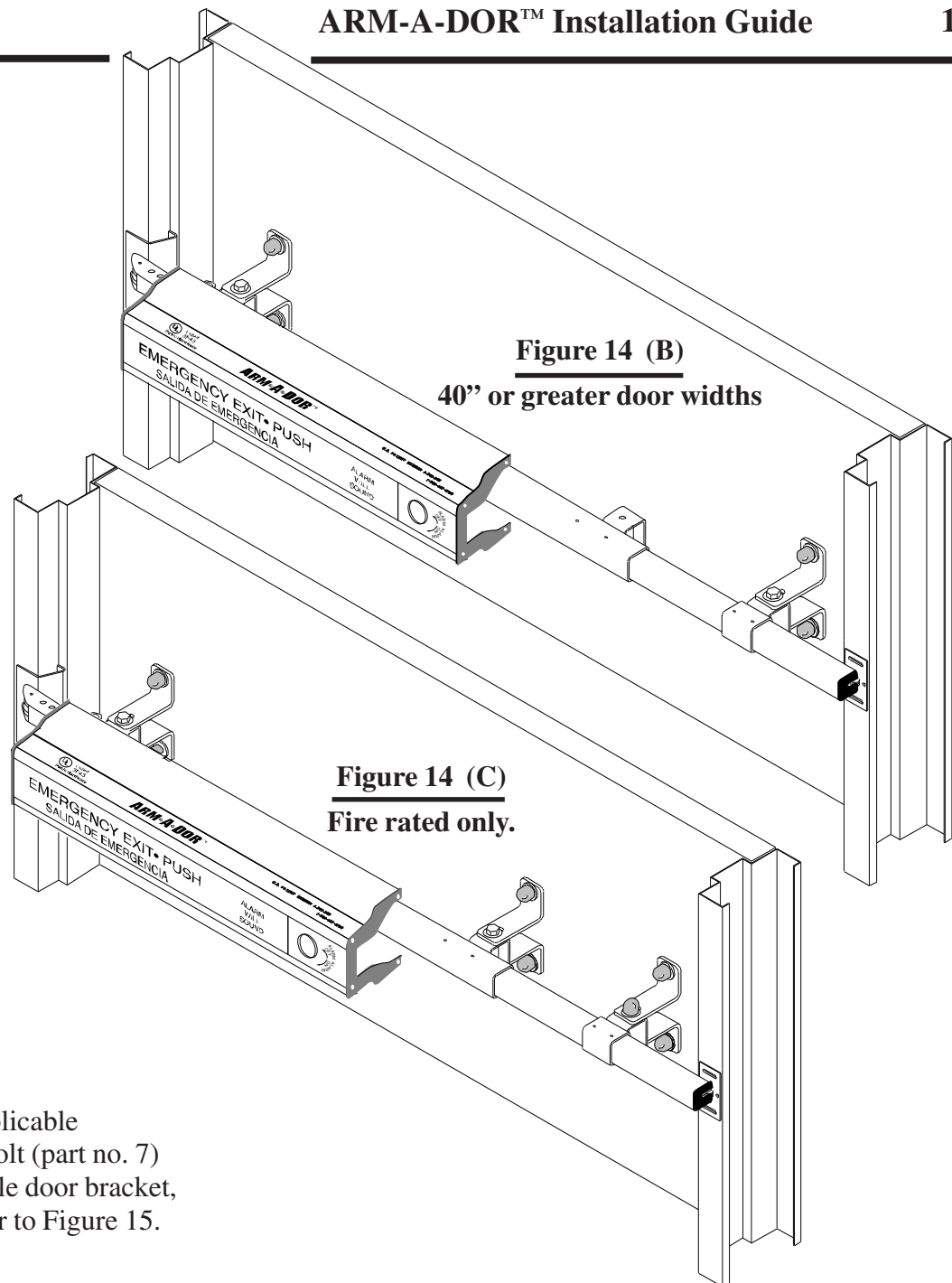

Figure 14 (B)
40" or greater door widths

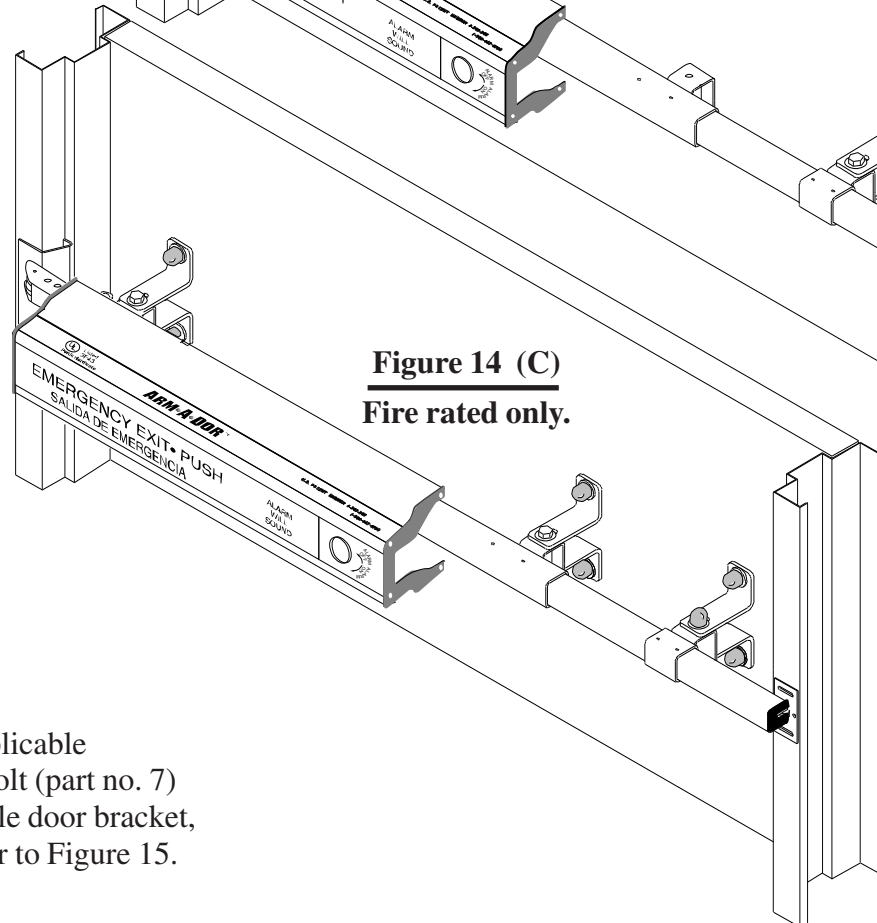
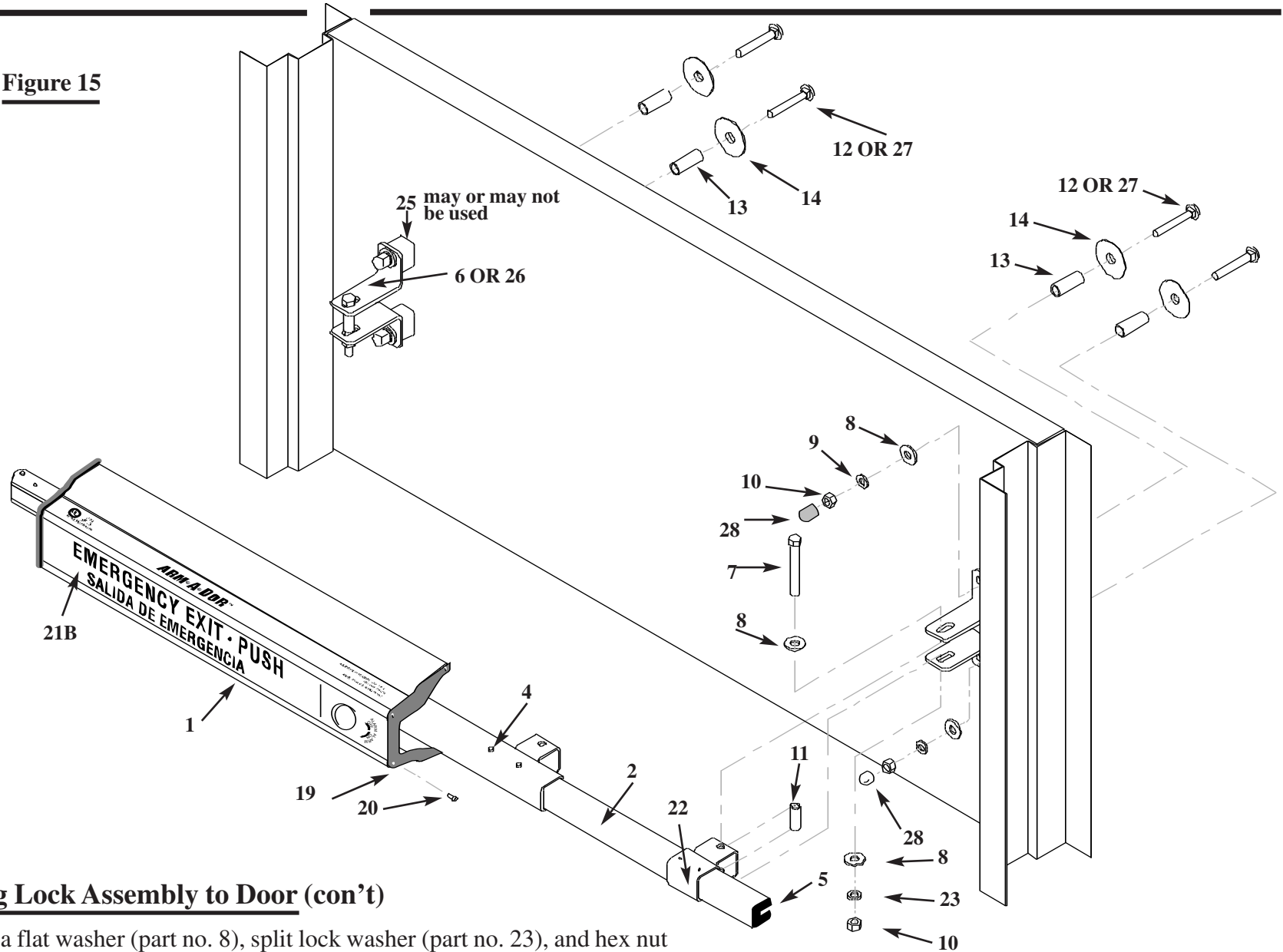

Figure 14 (C)
Fire rated only.

Attaching Lock Assembly to Door

1. If using the tailpiece collar, slide the collar onto the tailpiece (part no. 2). Tailpiece collar will be secured after all adjustments are complete.
2. Place support sleeve(s) (part no. 11) inside the applicable welded square bracket(s), then insert a hex head bolt (part no. 7) through a flat washer (part no. 8) into the applicable door bracket, and welded square bracket of assembly lock. Refer to Figure 15.

Figure 15



Attaching Lock Assembly to Door (con't)

3. Place a flat washer (part no. 8), split lock washer (part no. 23), and hex nut (part no. 10) onto hex head bolt protruding through the welded square bracket and door bracket. Hand tighten leaving hardware loose enough to adjust lock position.
4. If using Low Profile Kit, then refer to kit for further instructions, otherwise continue to next step.

E. Mounting Lock Assembly (con't)

Making Final Adjustments

1. Close the door and release the lock (for manual models: pull push pad, for automatic models: push on the bump rod/extension rod) so that AAD locks and spans the width of the door frame.
2. On the strike end measure end of the roller bearing to the inside door frame stop, the roller bearing should clear the door frame stop by no more than 1/8" as the door opens.
3. Adjust the position of AAD (left or right) until the measurements match.

Securing the Bolts

1. Tighten the hex nuts on the carriage bolts with a 9/16" wrench. Make sure the lock washers are fully compressed.
2. Press the four (4) gray vinyl caps (part no. 28) over the end of the carriage bolts and nuts. Fire-rated models on doors over 40" wide use six (6) gray vinyl caps.

F. Installing the Strike Plate and Release Bracket

Installing Strike Plate

1. Position strike plate (part no. 15) on the lock side of the door by centering it under the roller bearing. Mark the center of the holes on the door frame (Reference Figure 17).

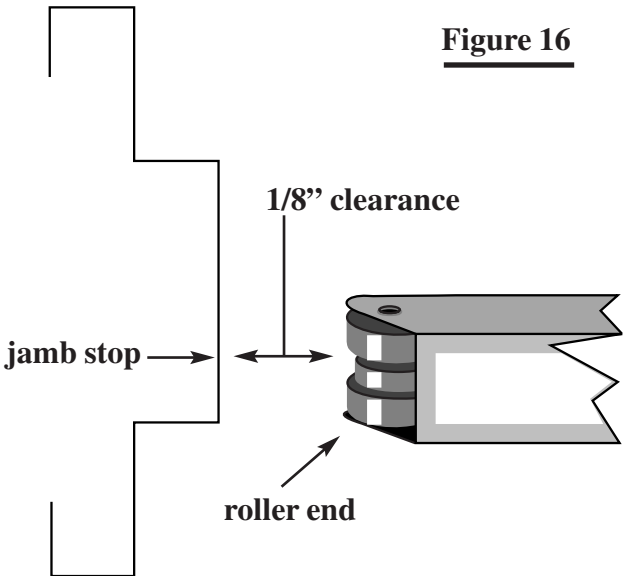

Figure 16

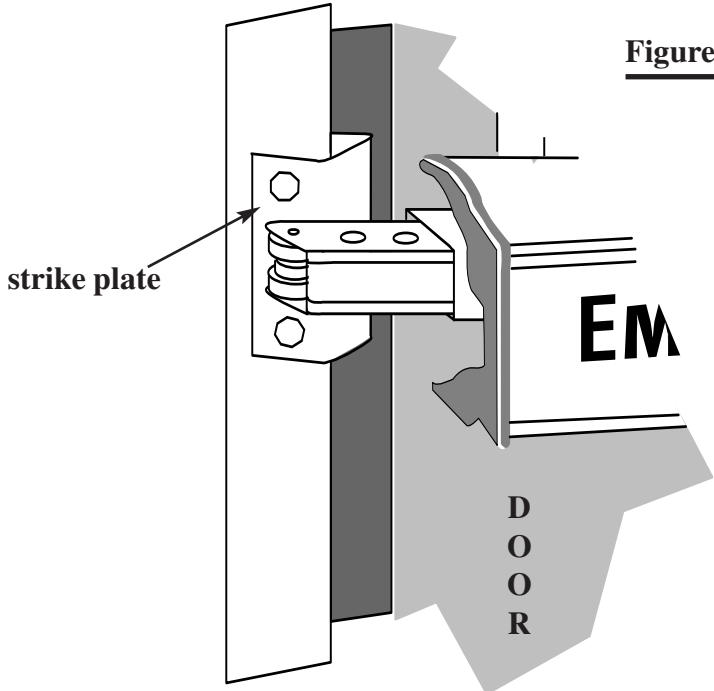

Figure 17

F. Installing the Strike Plate and Release Bracket (con't)

Installing Strike Plate (con't)

- Using 5/16 nut driver and drill, attach strike plate to the door frame with two (2) self-drilling screws (part no. 17) and star lock washers (part no. 24). Drill slowly to avoid stripping or over-tightening screws.
Note: If the frame is filled with concrete, drill clearance holes using 1/8" masonry bit.
- Push (not on push bar) the Arm-A-Dor assembly flush against door frame, sliding the two mounting bolts back into the door bracket slots. Tighten the nuts using a 9/16" wrench.

Installing Release Bracket (Auto unit only)

- Position the release brackets (part no. 16) on the hinged side of door frame by centering the fin in the slot of the tailpiece (Reference Figure 18). Mark the center of the slots on the door frame.
- Using a 5/16" nut driver and drill, attach the release bracket to the door frame using two (2) self drilling/tapping screws (part no. 17) and star lock washers (part no. 24). Drill slowly to avoid stripping or over-tightening screws.
Note: If the frame is filled with concrete, drill clearance holes using 1/8" masonry bit.
- Push (not on push bar) the Arm-A-Dor assembly flush against door frame, sliding the two mounting bolts back into the door bracket slots. Tighten the nuts using a 9/16" wrench.
- Check the door operation. Adjust, if necessary, to ensure that the extension rod contacts the release bracket fin, and relocks the unit each time the door closes.
Note: Make sure the lock does not release before the roller bearing contacts the sloped area on the strike plate.
- After the final adjustment, secure the release bracket with the third self-tapping screw and star lock washer into the center hole using a nut driver and drill.

Figure 18

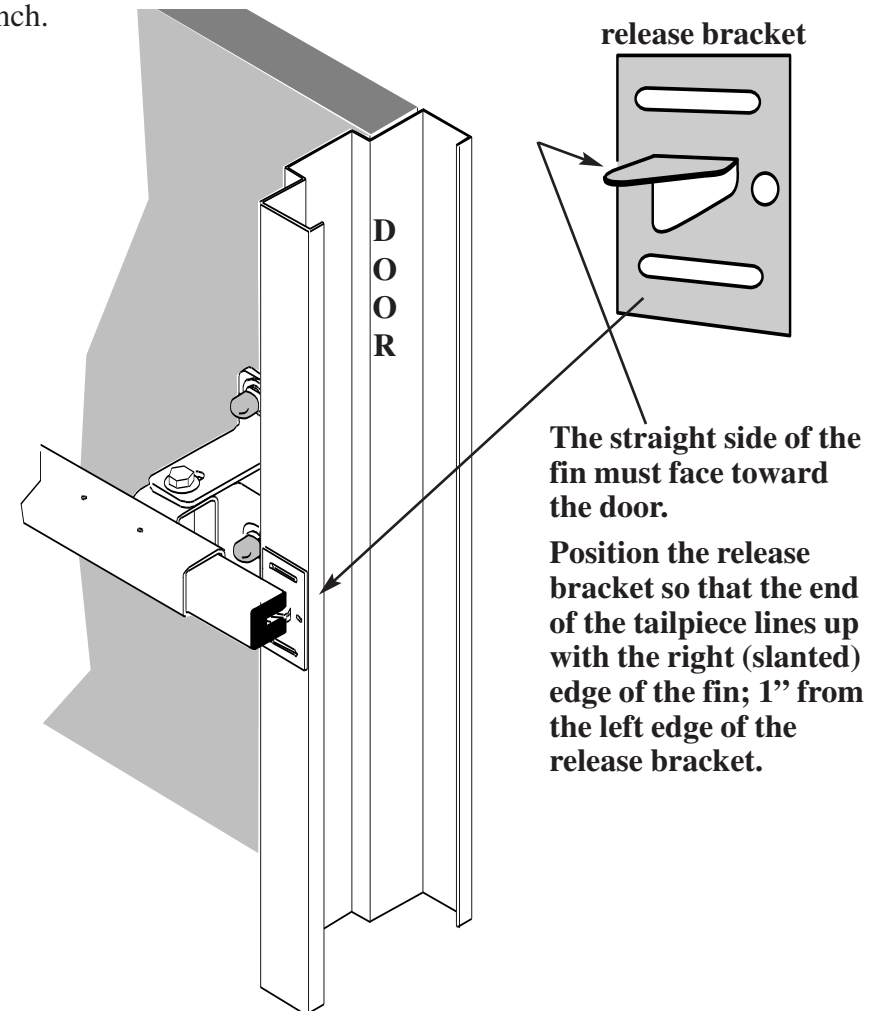

G. Attaching the Tailpiece End Cap

Insert the plastic end cap (part no. 5) into the end of the tailpiece, matching the contours of the two pieces and making sure it is secure inside the tailpiece.

H. Checking Door and Alarm Operation

Checking Door Operation

The door should now be secure with less than 1/8" clearance between roller bearings and the strike plate. If too tight against the strike plate or release bracket, loosen nuts on the door brackets on the tight side, adjust lock, and retighten. Be sure to allow approximately 1/8" clearance between the tailpiece and door frame (stationary end), and 1/8" clearance between the roller bearings and strike plate (active end).

Checking Alarm Operation (Alarm Units Only)

Rearm alarm unit by turning the key to the armed position. The alarm will beep several times, and the Red LED in the middle of the push pad will flash rapidly for twenty seconds. It will then flash every ten seconds, indicating the system is armed.

**Installation is Now Complete!!
Deliver the Keys and Owner's Guide
to the Store Manager!!**

dormakaba 

Corporate Headquarters

6161 East 75th Street
Indianapolis, IN 46250 USA

Technical Support: 800-847-6750
www.precisionhardware.com



PRECISION